

EX-7 series

HITACHI

Reliable Solutions

EX1200

Hitachi Construction Machinery Group

LANDCROS

Japanese Excellence—Reliable Solutions



## HYDRAULIC EXCAVATOR

**Model Code:** EX1200-7 (Fuel Consumption Optimization)  
**Engine Rated Power:** Cummins: 567 kW (770 PS, 760 HP)  
**Operating Weight:** Loading Shovel: 118 000 kg (260 000 lb.)  
Backhoe: 117 000 kg (258 000 lb.)  
BE-front: 118 000 kg (260 000 lb.)  
**Bucket Capacity:** Loading Shovel: ISO 7546:1983 (Heaped 2:1)  
: 5.9-7.5 m<sup>3</sup> (7.7-9.8 yd<sup>3</sup>)  
Backhoe: ISO 7451:2007: 5.2 m<sup>3</sup> (6.8 yd<sup>3</sup>)  
BE-front: ISO 7451:2007: 7.0-8.0 m<sup>3</sup> (9.2-10.5 yd<sup>3</sup>)

**Model Code:** EX1200-7B (Tier 4 Final / EU Stage V)  
**Engine Rated Power:** Cummins: 567 kW (770 PS, 760 HP)  
**Operating Weight:** Loading Shovel: 120 000 kg (263 000 lb.)  
Backhoe: 119 000 kg (261 000 lb.)  
BE-front: 120 000 kg (263 000 lb.)  
**Bucket Capacity:** Loading Shovel: ISO 7546:1983 (Heaped 2:1)  
: 5.9-7.5 m<sup>3</sup> (7.7-9.8 yd<sup>3</sup>)  
Backhoe: ISO 7451:2007: 5.2 m<sup>3</sup> (6.8 yd<sup>3</sup>)  
BE-front: ISO 7451:2007: 7.0-8.0 m<sup>3</sup> (9.2-10.5 yd<sup>3</sup>)

*Introducing the*  
**NEW EX1200-7**

Hitachi Construction Machinery's EX-7 series is refined based on the expertise we have cultivated over the years, integrating intelligence, safety and ultimate efficiency.

The EX1200-7 is a unique excavator within the Hitachi Construction Machinery range, adapting to many different operations. At its core lies clever and complex engineering; on the surface is a beautifully simple, operator-friendly machine.





**AUTO-IDLE**

When the machine is in neutral, auto-idle reduces engine speed to save on fuel consumption. If the control levers are operated, the engine will immediately return to the designated speed set by the engine control dial.

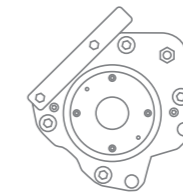

**MAIN PUMP ELECTRIC REGULATORS**

Each individually controlled hydraulic pump utilizes its own electric regulator. This delivers enhanced engine power, lower fuel consumption, and more efficient performance.

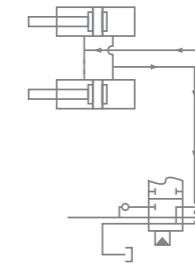

**HYDRAULIC REGENERATION CIRCUIT**

The boom, arm and bucket are fitted with a flow regeneration valve to reduce power requirements from the hydraulic system and engine, lowering fuel consumption and improving pump life.

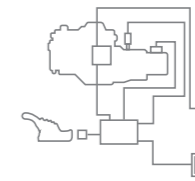

**ENGINE-PUMP (E-P) CONTROL**

Hitachi Construction Machinery's computer-aided Engine-Pump (E-P) Control achieves optimum productivity from the engine and hydraulic pumps. The innovative system senses load demand and controls engine and pump output to match the work being performed, maximizing operating efficiency and lowering fuel costs for large workloads.

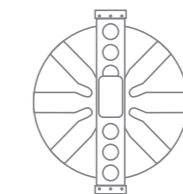

**HYDRAULIC OIL COOLER SYSTEM**

A redesigned hydraulic oil cooler with variable speed fan reduces energy demand and creates a more reliable hydraulic system. The oil cooler is kept separate from the radiator to keep hydraulic oil cool more effectively. Time and effort spent cleaning is drastically reduced, and service life of hydraulics is extended.



**RADIATOR FAN MOTOR**

The radiator fan is now driven by a hydraulic system, replacing the previous mechanical drive system. The fan automatically adjusts to meet engine requirements, creating an optimized cooling system with less horsepower demand and less operational noise.

*designed for*  
**SUSTAINABILITY**

Hitachi Construction Machinery's latest energy optimizing features provide a sustainable solution for the mining industry. The EX1200-7 includes electronically controlled hydraulic pumps, an optimized cooling package, enhanced hydraulic circuits, and a choice of emission configurations to meet regulatory requirements. The result is an environmentally conscious machine that doesn't compromise on performance.

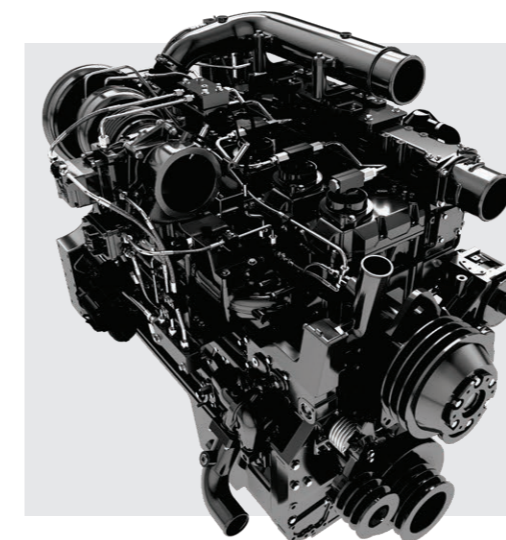

**DIESEL DRIVERS**

**EX1200-7 (FCO)**

The EX1200-7 model, equipped with Cummins FCO\* (Non-Certified) engine that optimizes fuel consumption.

**CUMMINS**

Cummins QSK23, 567 kW (770 PS, 760 HP)

\*FCO: Fuel Consumption Optimization

**EX1200-7B (TIER 4 FINAL/EU STAGE V)**

The EX1200-7B model, equipped with US EPA Tier 4 Final / EU Stage V emission regulations-compliant Cummins engine.

**CUMMINS**

Cummins QSK23 with SCR (Selective Catalytic Reduction) after-treatment system, 567 kW (770 PS, 760 HP)

# designed for PRODUCTIVITY

The EX-7 series of excavators embrace Hitachi Construction Machinery's latest advancements in design, performing consistently to meet the tough demands of the mining industry.

Engineered from the ground up to strike a balance between productivity and reliability, the EX1200-7 sets a new standard. Designed with precision, Hitachi Construction Machinery's meticulous craftsmanship delivers a robust and adaptable solution for all types of operation.

## FRONT ATTACHMENT

With a front attachment design that improves machine performance, the EX1200-7 can achieve superior productivity compared to the previous model under several digging profiles.

The boom and arm are welded, utilizing a full-box section design to evenly distribute stress and provide ease of maintenance.

The front attachment is optimized for the bucket design to achieve higher operating efficiency. It can be controlled with absolute precision while requiring little to no effort from the operator.

## BUCKET DESIGN

The bucket design is optimized for excavator performance and longevity, achieving long-term structural integrity and achieving higher productivity.

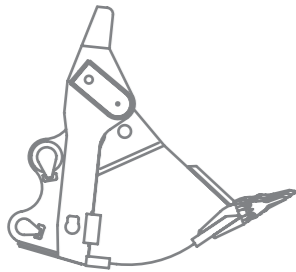

### LOADING SHOVEL EXCAVATING FORCE

**Arm crowding force on ground**  
572 kN (58 300 kgf, 129 000 lbf.)

**Bucket digging force**  
682 kN (69 600 kgf, 153 000 lbf.)

## BUCKET CONTROL

The bucket dumping angle can be freely adjusted for efficient dumping. This reduces shock to the dump body for longer service life and lower repair costs.

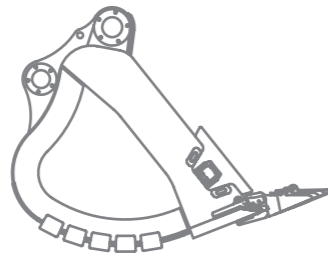

### BACKHOE EXCAVATING FORCE

**Arm crowding force**  
440 kN (44 800 kgf, 98 900 lbf.)

**Bucket digging force**  
496 kN (50 600 kgf, 112 000 lbf.)

### BACKHOE BE EXCAVATING FORCE

**Arm crowding force**  
437 kN (44 500 kgf, 98 200 lbf.)

**Bucket digging force**  
557 kN (56 800 kgf, 125 000 lbf.)



## EXCAVATION

The bucket digging profile allows a wide working area, ranging from below ground level to above cab height. There is no need for bucket repositioning and travelling to suit different job requirements, which boosts operating efficiency.

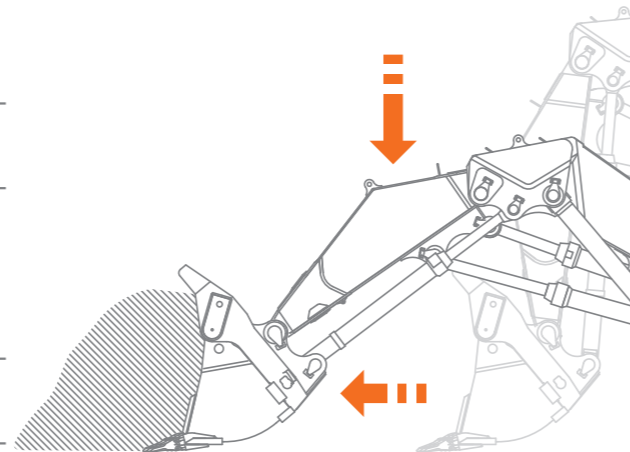

## AUTO-LEVELING MECHANISM FOR LOADER APPLICATION

The control of both the arm and boom is achieved through a Hitachi Construction Machinery proprietary leveling cylinder mechanism, using just one arm lever. This means the bucket can automatically be pushed out horizontally using a single movement. Potential energy created from the front weight is recycled as level cylinder thrust and added to the arm digging power. This allows for higher digging power, especially at the end of a stroke, improving work performance.

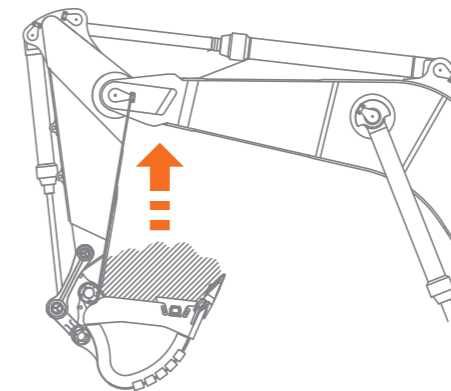

## AUTO-POWER LIFT

If load to the hydraulic system becomes excessive while the boom is being lifted, an automatic change in the main relief pressure setting will increase lifting power, improving operability and efficiency.



### SELECTABLE BOOM MODE

Two boom modes can be selected with the Boom Mode switch. Power Mode yields higher digging capability by increasing boom lower force for better penetration; Comfort Mode decreases boom lower force for less stress to the structure and smoother operation.

## designed for **OPERATOR CONTROL**

The EX1200-7 is not only designed to provide a comfortable experience, it also allows for excellent control. Intuitive and advanced features empower the operator to personalize and streamline their work environment for improved workflow and better productivity.



### MULTI-FUNCTIONAL DISPLAY

A multi-functional display provides key machine information, performance indicators, and on-board troubleshooting functionality with an integrated dial switch interface and 7-inch, high definition, color, multi-monitor screen. The display is fitted with an LED backlight to improve clarity and reduce reflective glare. 32 languages are provided for easier control and recognition.



### MULTI-FUNCTIONAL CONTROLLER

A dial type multi-functional controller makes operation easy and intuitive. Frequently used switches are located on the right hand side console panel within easy reach of the operator.

### POWER BOOST SWITCH

When digging in hard rock environments, Power Boost Switch can be temporarily activated to increase pump pressure and maximize hydraulic power in the front attachment.

## designed for **SAFETY**

At Hitachi Construction Machinery, safety is paramount. This design philosophy, which has evolved over years of experience, is implemented in the EX1200-7 layout to create a safer and more maintainable machine.

Improved pathways, handrails, and dual isolator switch as standard all make for a safer working environment.

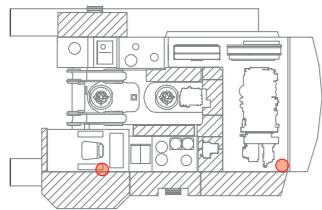

### **ENGINE STOP SWITCHES**

Engine stop switches located in both the engine room and cab allow for ease of access.

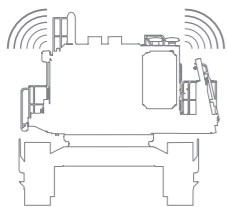

### **TRAVEL MOTION ALARM**

An audible alarm provides warning to surrounding vehicles and personnel when the excavator is travelling.



### **REAR VIEW CAMERA**

A rear view camera is located on the machine counterweight so the operator has a wider field of view when checking rearward on the cab's LCD monitor. This enhances safety during both swing and travel.

The operation status icons and rear view monitors can be displayed simultaneously without the hassle of having to switch between displays.



### **DUAL ISOLATOR SWITCH**

The conveniently located dual isolator switch offers the option to deactivate the engine and battery individually.

When inspections and maintenance are required, the battery isolator provides the benefit of isolating both the positive and negative terminals of the battery for a safe working environment. The engine isolator deactivates the engine starter motor while allowing battery power to the electric system for troubleshooting, enhancing safety and maintainability.



### **ACCESS AND WALKWAYS**

Anti-slip walkways and a specifically designed handrail system reduce the risk of tripping when maneuvering around the machine and provide ease of access for operators and maintenance personnel.

A slide ladder is provided as a standard feature, providing easy access to the machine from the ground level.



## OPERATOR CABIN

Laminated windows on the front of the cab and tinted windows on the sides reduce heat, glare and harmful UV rays. Sound-suppression further enhances ergonomics and comfort for the operator. The Level II Operator Protective Guard (OPG) provides secure protection from falling objects, ensuring operator safety.

## AMENITIES

Operator amenities are designed to maximize comfort and productivity and include hot and cool box, multiple drink holders, 12V power supply, stereo speakers, external audio input, audio device storage box, large storage space to the seat rear, and door-activated dome light.



# designed for OPERATOR COMFORT

The EX1200-7 is engineered with a superior level of comfort for an operator experience like no other. The ergonomic layout, intelligent Multi-Functional Display, and enhanced climate control system create an operating environment that lessens fatigue and increases productivity.

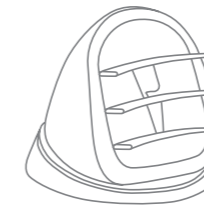

### CLIMATE CONTROLLED AIR CONDITIONING

The pressurized cab's climate controlled air conditioning helps to overcome environmental extremes. Optimized filtering of interior and exterior air combined with the new flexi-vent system provides a personalized and balanced environment that meets operator demands.



### OPERATOR SEAT

Specifically designed for use in the mining industry, the cab's weight-adjusting cushioned seat allows the operator to customize suspension settings. An optional air suspension seat can be activated by a single switch, and will automatically calculate optimal cushioning according to operator weight. These features enhance comfort and minimize vibration.

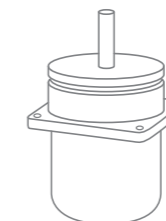

### FLUID-FILLED ELASTIC MOUNTS

The cab rests on 6-point, support type, fluid-filled elastic mounts. These significantly reduce shocks and vibration for operator comfort, and improve cab durability. These mounts can easily be replaced from underneath the cab floor bed without needing to lift the cab.

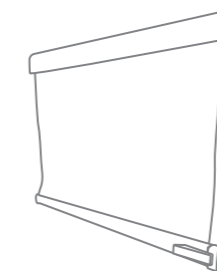

### ROLL SCREENS (OPTIONAL)

Retractable front and side roll screens reduce heat buildup in the cab, improving efficiency of the climate controlled air conditioner for a superior operating environment.

*designed for*  
**EASE OF  
 MAINTENANCE**

Hitachi Construction Machinery believes in safe and simplified maintenance. That's why the EX1200-7's unique modular design, combined with spacious passageways and work platforms, provides clear access for daily upkeep and major component inspections.

Several innovative new features improve serviceability of the EX1200-7, providing the ease of maintenance functionality customers have come to expect from Hitachi Construction Machinery.



**MAINTENANCE ALERTS & TROUBLESHOOTING**

Each time the machine is turned on, the monitor will prompt regular maintenance. The operator can activate specific prompts to appear when needed for peace of mind. Error codes can be displayed on the main screen by authorized service personnel for quick troubleshooting.



**MAINTENANCE ACCESS**

Wide center walkways and open service areas offer ease of access for daily maintenance tasks and make engine, hydraulic, and electrical component inspections easy.



**CENTRALIZED FILTER SYSTEM**

Frequently accessed filters are now conveniently located in the center access way.

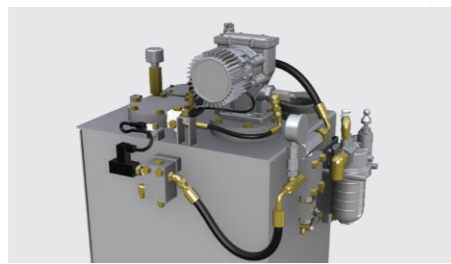

**AUTO-LUBRICATION SYSTEM (OPTIONAL)**

The EX1200-7 comes with the introduction of an optional auto-lubrication system for a bulk excavation front attachment, which supplies grease to the superstructure including bucket pins. The advanced system comes redesigned with a 95L (25 gal.) large capacity grease tank, new grease pump, in-line grease filter and breather with filter, resulting in a more reliable system with less downtime.

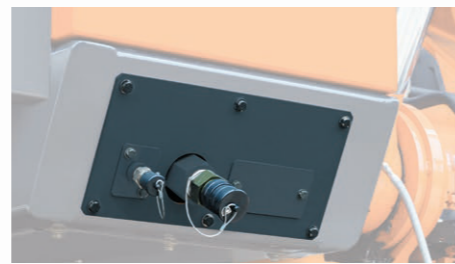

**FUEL FAST FILL PIPING (OPTIONAL)**

The optional fast-filling system provides easy access from the ground to refill fuel. The fast fill piping can also be fitted with an optional quick coupler.

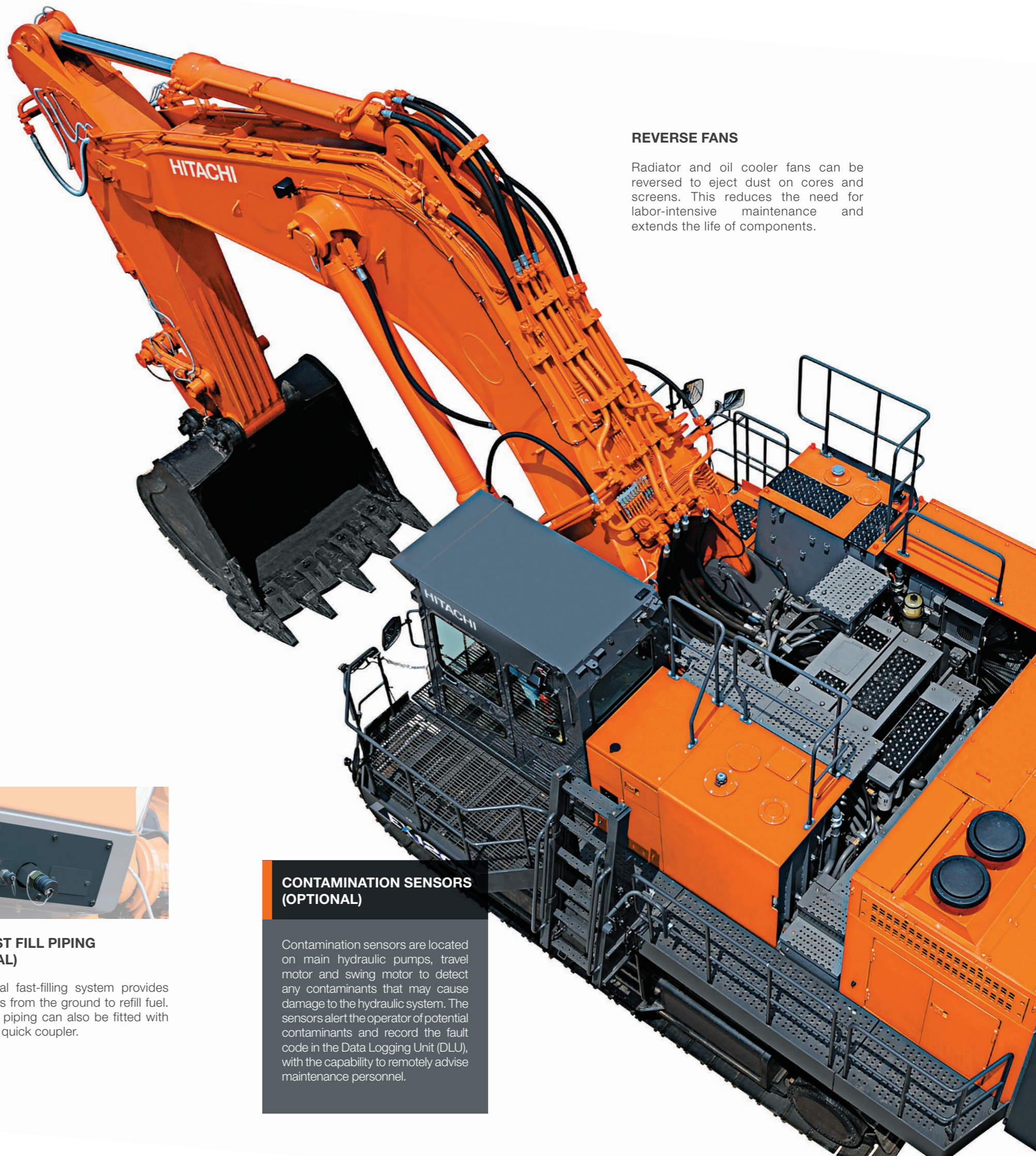

**REVERSE FANS**

Radiator and oil cooler fans can be reversed to eject dust on cores and screens. This reduces the need for labor-intensive maintenance and extends the life of components.

**CONTAMINATION SENSORS (OPTIONAL)**

Contamination sensors are located on main hydraulic pumps, travel motor and swing motor to detect any contaminants that may cause damage to the hydraulic system. The sensors alert the operator of potential contaminants and record the fault code in the Data Logging Unit (DLU), with the capability to remotely advise maintenance personnel.



**AUTOMATIC TRAVEL SHIFTING**

When the track identifies an excessive resistance such as hill climb or soft ground while traveling in high speed mode, the system automatically shifts to low speed for better traction. Once resistance is reduced, the travel shift reverts to original speed.



*designed for*  
**DURABILITY**

Longevity is a cornerstone of Hitachi Construction Machinery's EX-7 excavators. Advanced computer modelling, specialized forgings, and track shoes combine to provide a dependable and flexible solution for all mining operations.

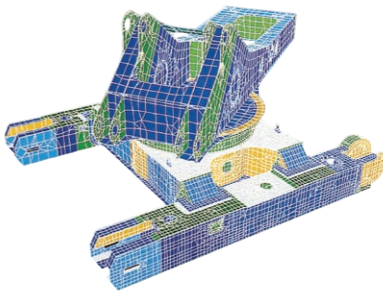

**RIGID BOX DESIGN**

Computer assisted analysis has been used to determine the most effective design for frame longevity, to ensure the machine withstands the demands of various mining operation.

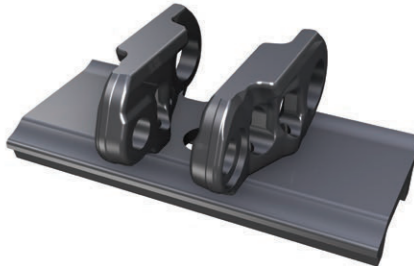

**TRACK SHOES**

Improved Hitachi Construction Machinery track link design mitigates premature failure of the master pin, increasing durability.



**CENTER TRACK FRAME**

Hitachi Construction Machinery's exclusive center track frame delivers optimal stress dispersion, through the use of specially designed forged steel parts, to reduce the chance of failure in critical high-stress areas. This guarantees a stronger frame with improved durability compared to the model prior to its adoption.

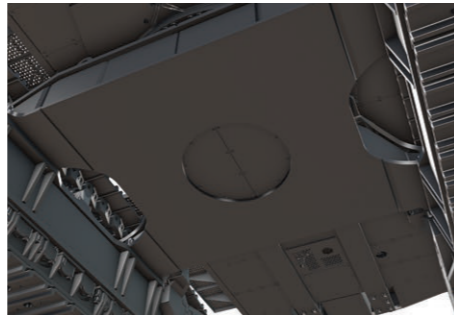

**FORGED SWING CIRCLE**

A forged swing circle distributes stress evenly around the most demanding areas of the component, improving machine sturdiness.

**CENTER FRAME UNDERGUARD (OPTIONAL)**

The newly designed heavy duty guard protects hoses located in the track center frame from rocks and debris ingress, providing extra protection and reliability.

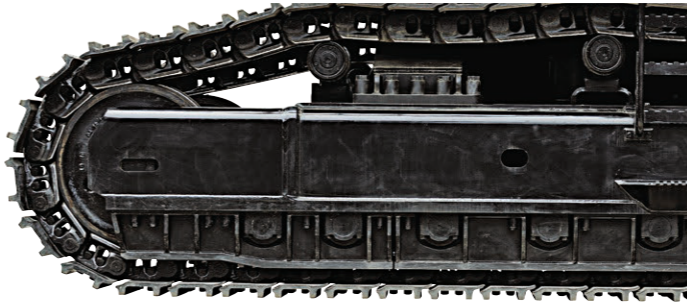

**OIL-FILLED ROLLERS & IDLERS**

The oil-filled idlers and upper and lower rollers eliminate the need for daily lubrication, helping reduce maintenance costs.



**FULL TRACK GUARD (OPTIONAL)**

A full track guard prevents link mistracking when the EX1200-7 is operating on a rocky surface for extra assurance.

## OPERATING LIGHTS

Strategically placed long-life LED working lights provide greater longevity and reliability for night operations.

## designed for **RELIABILITY**

Evolving from years of operational experience and engineering excellence, the Hitachi Construction Machinery EX-7 series of excavators continue to drive innovation in the mining industry. Advanced technology, enhanced durability, state-of-the-art safety features, and superior operational performance compared to the previous model combine to make the EX1200-7 a reliable mining solution.



### GREASE-LESS CENTER JOINT

The redesigned center joint employs the machine's hydraulic oil to self-lubricate, reducing the need for daily maintenance.



### FRONT ATTACHMENT HOSES

Hitachi Construction Machinery's hose design is based on a cyclic fatigue rate to maximize longevity and improve safety. Front attachment hoses have been rearranged from the traditional arch style to an underslung configuration to remove the need for clamping, reduce chafing and increase reliability.



### BUCKET LINKAGE

Floating pin design is adopted for bucket linkage. This helps to reduce wear by evenly distributing the load around the pin and minimizing dust ingress. A replaceable thrust plate minimizes maintenance time caused by extreme contact wear to the surface.

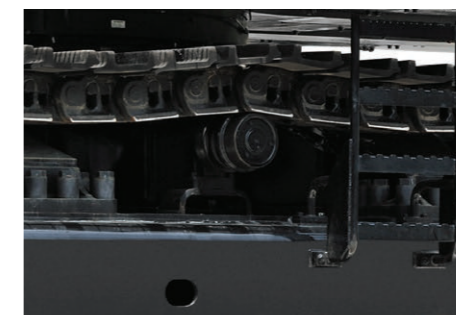

### UPPER ROLLERS

The EX1200-7 undercarriage has three single-sided upper rollers on each side of the track frame. These rollers maintain track shoe clearance and provide protection from debris buildup, reducing shoe and roller wear for a more reliable machine.

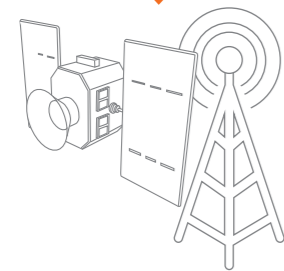

**SATELLITE / GPRS COMMUNICATION (OPTIONAL)**

Standard machine information is transmitted daily through either satellite or GPRS (General Packet Radio Service) communication, sending data directly to the Hitachi Construction Machinery Global e-Service platform to support the mining operation.

**Globale-Service**

Global e-Service is a Hitachi Construction Machinery web-based platform that sends vital machine information directly to the customer in an easy-to-understand format.

ANTENNA (GPRS) OR SATELLITE



*designed for*  
**INTELLIGENCE**

Hitachi Construction Machinery's EX-7 excavators connect physical features with digital technologies for seamless and intuitive operation. Extensive onboard sensors, diagnostic tools, real time data and advanced software allow the EX1200-7 to empower personnel with a better understanding of mining operations.

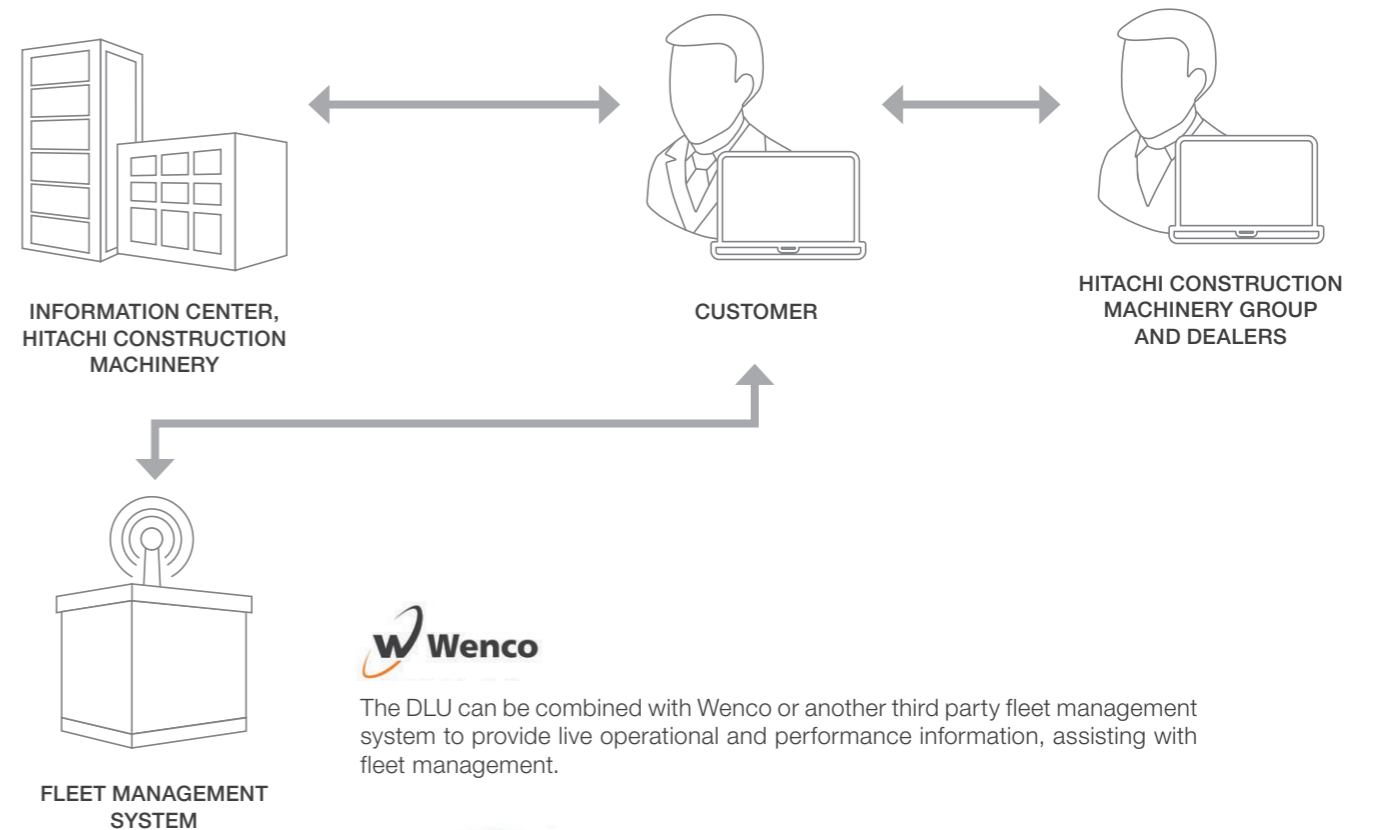

The DLU can be combined with Wenco or another third party fleet management system to provide live operational and performance information, assisting with fleet management.



**Aerial Angle (OPTIONAL)**

Aerial Angle provides the operator with a real-time continuous birds-eye view around their excavator. Cameras strategically mounted on the machine combine to a single aerial view of the EX1200-7 surroundings. Multiple screen display options can be selected on the cab's 12-inch Aerial Angle monitor for ease of operation.

# SPECIFICATIONS

## ENGINE

Model ..... Cummins QSK23-C (FCO, T4F / EU Stage V)  
 Rated power @1 800 min<sup>-1</sup>(rpm)  
 ISO 14396: 2002, gross.. 567 kW (770 PS, 760 HP)  
 Piston displacement ..... 23.2 L (1 420 cu.in.)

## HYDRAULIC SYSTEM

Main pumps..... 3 variable-displacement, swash plate type axial piston pumps  
 Max. oil flow ..... 3 x 520 L/min (3 x 134 gal./min)  
 Pressure setting..... 31.9 MPa (325 kgf/cm<sup>2</sup>, 4 630 psi)  
 Pilot pump ..... Gear pump  
 Max. oil flow ..... 56.0 L/min (14.8 gal./min.)  
 Fan pump ..... Variable-displacement, swash plate type axial piston pumps  
 Max. oil flow ..... 130.0 L/min (34.3 gal./min.)

## UPPER STRUCTURE

Swing speed ..... 5.2 min<sup>-1</sup> (rpm)  
 Fuel tank capacity ..... 1 700 L (449 gal.)  
 DEF tank capacity  
 (T4F / EU Stage V only) .. 145 L (38.3 gal.)

## UNDERCARRIAGE

Travel speeds ..... High: 0 to 3.5 km/h (0 to 2.2 mph)  
 Low: 0 to 2.4 km/h (0 to 1.5 mph)  
 Maximum traction force ... 707 kN (72 100 kgf, 159 000 lbf.)

## ATTACHMENTS LOADING SHOVEL

### Loading Shovel Bucket

Type*	Capacity (heaped)	Cutting Width	No. of teeth	Weight	Materials Density
	ISO 7546 :1983 (Heaped 2:1)				
GP	5.9 m <sup>3</sup> (7.7 yd <sup>3</sup> )	2 700 mm (8 ft. 10 in.)	5	10 900 kg (24 000 lb)	1 800 kg/m <sup>3</sup> (3 030 lbs./yd <sup>3</sup> ) or less
GP	6.5 m <sup>3</sup> (8.5 yd <sup>3</sup> )	2 900 mm (9 ft. 6 in.)	6	11 300 kg (24 900 lb)	1 800 kg/m <sup>3</sup> (3 030 lbs./yd <sup>3</sup> ) or less
HD	5.9 m <sup>3</sup> (7.7 yd <sup>3</sup> )	2 700 mm (8 ft. 10 in.)	5	11 500 kg (25 400 lb)	1 800 kg/m <sup>3</sup> (3 030 lbs./yd <sup>3</sup> ) or less
HD	6.5 m <sup>3</sup> (8.5 yd <sup>3</sup> )	2 900 mm (9 ft. 6 in.)	6	11 700 kg (25 800 lb)	1 800 kg/m <sup>3</sup> (3 030 lbs./yd <sup>3</sup> ) or less
LT	7.5 m <sup>3</sup> (9.8 yd <sup>3</sup> )	2 900 mm (9 ft. 6 in.)	6	11 900 kg (26 200 lb)	1 600 kg/m <sup>3</sup> (2 700 lbs./yd <sup>3</sup> ) or less

\* GP : General Purpose HD : Heavy Duty LT : Light Duty

## ATTACHMENTS BACKHOE

### Backhoe Bucket

Type*	Capacity (heaped)	Cutting Width	No. of teeth	Weight	Materials Density	Applicable Front
	ISO 7451:2007 (Heaped 1:1)					
GP	5.2 m <sup>3</sup> (6.8 yd <sup>3</sup> )	2 400 mm (7 ft. 10 in.)	5	6 800 kg (15 000 lb)	1 800 kg/m <sup>3</sup> (3 030 lbs./yd <sup>3</sup> ) or less	Boom 9.0 m (29 ft. 6 in.) Arm 3.6 m (11 ft. 10 in.)
HD	5.2 m <sup>3</sup> (6.8 yd <sup>3</sup> )	2 400 mm (7 ft. 10 in.)	5	7 000 kg (15 400 lb)	1 800 kg/m <sup>3</sup> (3 030 lbs./yd <sup>3</sup> ) or less	
GP	7.0 m <sup>3</sup> (9.2 yd <sup>3</sup> )	2 630 mm (8 ft. 8 in.)	5	8 900 kg (19 600 lb)	1 800 kg/m <sup>3</sup> (3 030 lbs./yd <sup>3</sup> ) or less	Boom 7.55 m (24 ft. 9 in.) Arm 3.4 m (11 ft. 2 in.)
HD	7.0 m <sup>3</sup> (9.2 yd <sup>3</sup> )	2 630 mm (8 ft. 8 in.)	5	9 100 kg (20 100 lb)	1 800 kg/m <sup>3</sup> (3 030 lbs./yd <sup>3</sup> ) or less	
LT	8.0 m <sup>3</sup> (10.5 yd <sup>3</sup> )	2 630 mm (8 ft. 8 in.)	5	9 100 kg (20 100 lb)	1 600 kg/m <sup>3</sup> (2 700 lbs./yd <sup>3</sup> ) or less	

\* GP : General Purpose HD : Heavy Duty LT : Light Duty

## WEIGHTS AND GROUND PRESSURE

### Loading Shovel

Equipped with 6.5 m<sup>3</sup> (ISO heaped) bottom dump bucket

Shoe type	Shoe width		Operating weight	Ground pressure
Double grousers	700 mm (28 in.)	FCO	118 000 kg	149 kPa (1.52 kgf/cm <sup>2</sup> )
		T4F	120 000 kg	152 kPa (1.54 kgf/cm <sup>2</sup> )

Ground pressures are based on ISO 16754

### Backhoe

EX1200-7: Equipped with 9.0 m boom, 3.6 m arm, and 5.2 m<sup>3</sup> (ISO heaped) bucket

Shoe type	Shoe width		Operating weight	Ground pressure
Double grousers	700 mm (28 in.)	FCO	117 000 kg	148 kPa (1.51 kgf/cm <sup>2</sup> )
		T4F	119 000 kg	150 kPa (1.53 kgf/cm <sup>2</sup> )
	900 mm (35 in.)	FCO	118 000 kg	116 kPa (1.18 kgf/cm <sup>2</sup> )
		T4F	120 000 kg	118 kPa (1.20 kgf/cm <sup>2</sup> )

Ground pressures are based on ISO 16754

EX1200-7 BE front: Equipped with 7.55 m BE boom, 3.4 m BE arm, and 7.0 m<sup>3</sup> (ISO heaped) bucket

Shoe type	Shoe width		Operating weight	Ground pressure
Double grousers	700 mm (28 in.)	FCO	118 000 kg	149 kPa (1.52 kgf/cm <sup>2</sup> )
		T4F	120 000 kg	152 kPa (1.54 kgf/cm <sup>2</sup> )
	900 mm (35 in.)	FCO	119 000 kg	117 kPa (1.15 kgf/cm <sup>2</sup> )
		T4F	121 000 kg	119 kPa (1.21 kgf/cm <sup>2</sup> )

Ground pressures are based on ISO 16754

## WORKING RANGES

### Loading Shovel

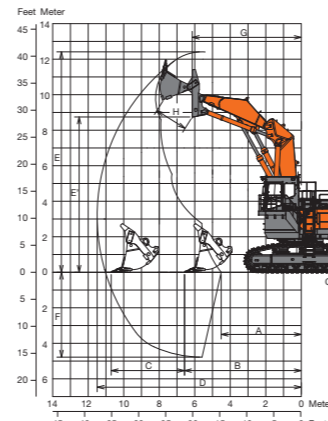

	Bucket capacity ISO7546:1983 (Heaped 2:1)	6.5 m <sup>3</sup> (8.5 yd <sup>3</sup> )
A	Min. digging distance	4 510 mm (14 ft. 10 in.)
B	Min. level crowding distance	6 580 mm (21 ft. 7 in.)
C	Level crowding distance	4 370 mm (14 ft. 4 in.)
D	Max. digging reach	11 500 mm (37 ft. 9 in.)
E	Max. cutting height	12 410 mm (40 ft. 9 in.)
E'	Max. dumping height	8 750 mm (28 ft. 8 in.)
F	Max. digging depth	4 780 mm (15 ft. 8 in.)
G	Working radius at max. dumping height	6 140 mm (20 ft. 2 in.)
H	Max. bucket opening width	1 880 mm (6 ft. 2 in.)
	Arm crowding force on ground	572 kN (58 300 kgf, 129 000 lbf.)
	Bucket digging force	682 kN (69 600 kgf, 153 000 lbf.)

### Backhoe

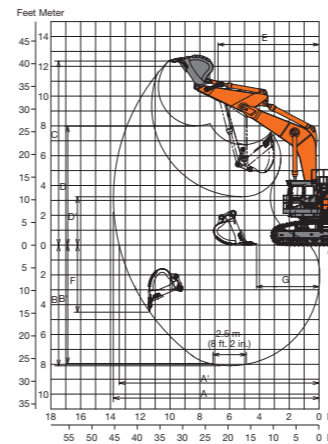

	7.55 m (24 ft. 9 in.) BE-boom	9.0 m (29 ft. 6 in.)
	3.4 m (11 ft. 2 in.) BE-arm	3.6 m (11 ft. 10 in.)
A	Max. digging reach	13 790 mm (45 ft. 3 in.)
A'	Max. digging reach (on ground)	13 410 mm (44 ft.)
B	Max. digging depth	8 100 mm (26 ft. 7 in.)
B'	Max. digging depth (2.5m level)	7 960 mm (26 ft. 1 in.)
C	Max. cutting height	12 340 mm (40 ft. 6 in.)
D	Max. dumping height	8 010 mm (26 ft. 3 in.)
D'	Min. dumping height	3 220 mm (10 ft. 7 in.)
E	Min. swing radius	6 770 mm (22 ft. 3 in.)
F	Max. vertical wall	4 440 mm (14 ft. 7 in.)
G	Min. level crowding distance	4 210 mm (13 ft. 10 in.)
	Bucket digging force (ISO 6015:2006)*	557 kN / 56 800 kgf (125 000 lb.)
	Arm crowed force (ISO 6015:2006)*	437 kN / 44 500 kgf (98 200 lb.)

\*This is the calculated value at the loading point (Cutting Edge) conforming to ISO.

## DIMENSIONS

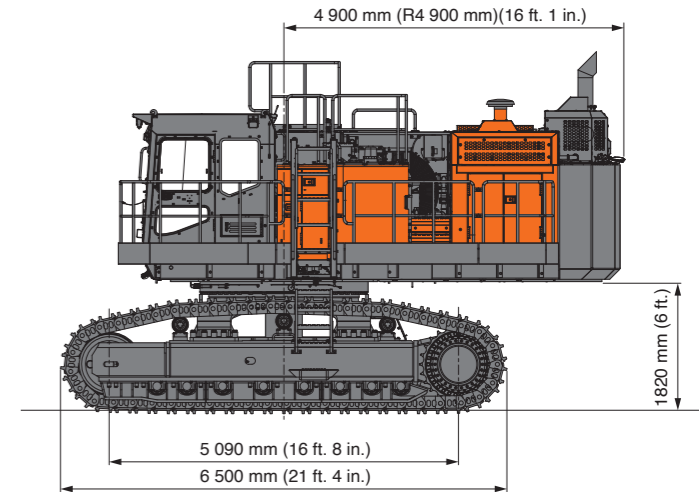
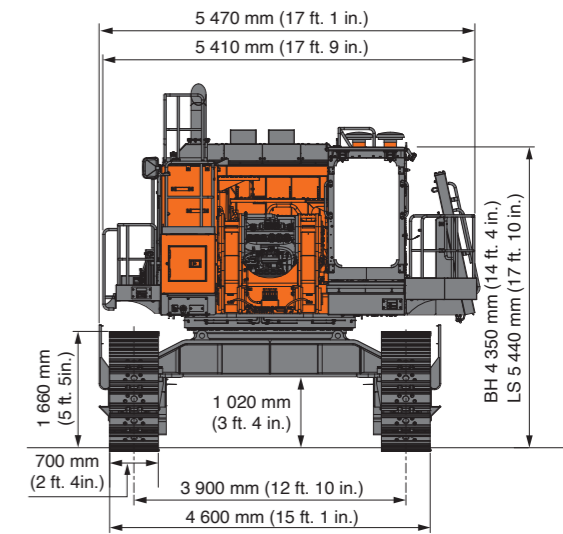

## PASS MATCH

Best match: 4-6 passes  
 Potential match: 3-8 passes

Model		60t class truck	100t class truck	EH3500AC-3	EH4000AC-3
EX1200-7	BH 7.0 m <sup>3</sup> (9.2 yd <sup>3</sup> )	5			
	LD 6.5 m <sup>3</sup> (8.5 yd <sup>3</sup> )	6			
EX2000-7	BH 12.0 m <sup>3</sup> (15.7 yd <sup>3</sup> )	3	5		
	LD 12.0 m <sup>3</sup> (15.7 yd <sup>3</sup> )	3	5		
EX2600-7	BH 17.0 m <sup>3</sup> (22.2 yd <sup>3</sup> )		3	6	8
	LD 15.0 m <sup>3</sup> (19.6 yd <sup>3</sup> )		4	8	

# EQUIPMENT

## STANDARD EQUIPMENT

Standard equipment may vary by country, so please consult your Hitachi Construction Machinery dealer for details.

### ENGINE

- Alternator belt auto-tensioner
- Auto-idle system
- Auto shut down control
- Cartridge-type engine oil filter
- Cartridge-type fuel filter (only for T4F / EU Stage V)
- Coolant filter
- Dry-type air filter with clean dust cup
- Eco control
- Element -type fuel filter
- Emergency engine stop system
- Fan guard
- Isolation-mounted engine
- Overheat prevention control
- Power mode switch control (ECO/PWR/HP)
- Radiator, air cooler and oil cooler with dust protective net
- SCR muffler (T4F / EU Stage V only)
- 140A alternator

### HYDRAULIC SYSTEM

- Auto power lift control (BH)
- Boom mode selector system
- Control valve with main relief valve
- Engine speed sensing system
- E-P control system
- Full-flow filter
- HIOS III B (Human & Intelligent Operation System)
- Line filter (Delivery filter)
- Overheat prevention control
- Pilot filter
- Pump drain filter
- Reverse Fan system
- Suction filter
- Transmission oil cooling system

### CAB

- Adjustable armrests
- Adjustable reclining seat
- All-weather sound-suppressed steel integrated cab

- Ashtray
- Auto controlled air conditioner\* with defroster
- Auto-idle switch
- Auto-tuning AM-FM radio
- Cigarette lighter
- Digital clock
- Dome light linked to door
- Drink holder with hot and cool functions
- Electrical horn
- Engine control dial
- Evacuation hammer
- External input port (Aux terminal)
- Floor mat
- Footrest
- High cab kit (for Loading shovel)
- Large storage space
- Hot and cool box
- Intermittent wiper interlocked with front windshield washer
- Laminated glass windshield
- OPG top guard level II (ISO 10262:1998)
- Pilot control shut-off lever
- Rearview mirror
- Reinforced/tinted (Green color) glass side and rear windows
- Seat belt
- Small caddy
- Speakers at the side
- USB supply
- 12 V power supply

### MONITOR SYSTEMS

- Meters:
  - Auto-idle
  - DEF gauge (only for T4F / EU Stage V)
  - Engine coolant temperature gauge
  - Fuel gauge
  - Hour meter
  - Indicator

### DATA LOGGING SYSTEM

- DLU (Data-logging unit) continuously records performance of the engine and

the hydraulic system.

The record can be down-loaded by PC. And for Fleet management system (Provided by Wenco etc.) connection\*\*

### LIGHTS

- 1 boom LED light
- 1 step LED light
- 2 cab LED lights
- 2 counterweight LED lights
- 2 working LED lights

### UPPERSTRUCTURE

- Centralized lubrication system for swing bearing
- Control valves with main relief valves and port relief valves
- Dual isolator switch
- Electric grease gun with hose reel
- Rear view camera
- Slow return orifices and make up valves for cylinder circuits
- Undercover
- 18 000 kg (39 683 lb.) counterweight

### UNDERCARRIAGE

- Hydraulic (Grease) track adjuster with shock absorbing recoils spring
- Spring-set/hydraulic-released disc type parking brake
- Track and idler guards
- Travel motor cover
- 700 mm (28 in.) shoe

### MISCELLANEOUS

- Auto-lubrication system for front-attachment
  - BH, BE front : Except bucket arm joint pin
  - LD front : Include bucket arm joint pin
- Dual isolator switch
- Elevated cab (for Loading Shovel)
- ISO conforming stairs and handrails
- Slide ladder
- Slip resistance plate
- Wide side walk

## OPTIONAL EQUIPMENT

Optional equipment may vary by country, so please consult your Hitachi Construction Machinery dealer for details.

- Additional fuel filter
- Additional travel motion alarm
- Additional 1 boom LED light
- Additional 2 Cab LED lights
- Additional 1 Cab rear Halogen light
- Aerial angle
- Aerial angle calibration kit
- Air suspension & heater seat
- Bucket auto lubrication system (STD/BE front)
- CAB front guard
- Center frame under guard
- Cold weather package
- Communication system\*\*
  - GPRS communication system
  - Satellite data transmitting system
- Contamination sensor
- Electric fuel refilling pump device
- Fuel refilling piping
- Full track guard
- Harness (DTU)
- Hand rail on the oil cooler, Radiator, counter weight, air cleaner
- High altitude application\*\*\*
- High cab kit (for Backhoe)
- Large sized air cleaner
- Marine specification
- Pre-cleaner
  - Full view type
  - Top spin type
- Right and left side cameras
- Roll screens

- Standard tool kit
- Sun visor
- Swing alarm
- Toolbox
- Travel motion alarm device
- Travel motion alarm device (Single)
- Travel motion alarm device (Double)
- 900 mm (35 in.) shoe (BH only)

\*: Contains fluorinated greenhouse gases, Refrigerant type: HFC-134a, GWP: 1430, Amount: 1.25kg (2.76 lb.), CO2e: 1.79 tonnes (1.97 tons).

\*\* : The availability of the system depends on licensing regulations in each country. Please contact Hitachi Construction Machinery dealer for more information.

\*\*\*: Engineered on request

Before using a machine with a satellite communication system or telecommunication system, please make sure that the satellite communication system complies with local regulations, safety standards and legal requirements. If not so, please make modifications accordingly.

These specifications are subject to change without notice. Illustrations and photos show the standard models, and may or may not include optional equipment, accessories, and all standard equipment with some differences in color and features. Before use, read and understand the Operator's Manual for proper operation.